

PENNSYLVANIA & BERWIND RR EMPLOYEE TIMETABLE

P&B MAIN TRACK (E)				
MP	BLOCK LIMIT	STATION	SIDING CAPY FEET (CARS)	RULES
0.0	GRAFTON YARD (Grafton Industrial Track)	YARD	YD
2.2	N&W JCT (N&W Joint Yard)	YD
2.4	GRAFTON (Begin/End Block)	MBS
5.2	BLS	CUMBERLAND	MBS
6.5	BLS	HIGHLAND (Highland Industrial Track)	3800 (66)	MBS
8.4	TROUT RIVER	MBS
8.7	BLS	TROUT	3640 (63)	MBS
9.6	PAINT CREEK JCT (Paint Creek Branch)	MBS
10.9	BLS	GRUNDYS (Grundys Spur)	600 (11)	MBS
10.9	PLEASANTVILLE JUNCTION (Pleasantville Secondary)	MBS
12.3	BLS	MT UNION	MBS
14.5	HUNTINGDON (Huntingdon Paper Spur)	2110 (23)	MBS
16.5	BLS	EVERETT	6500 (112)	MBS
17.9	BLS	MAPLETON	MBS
21.5	ALLEGHENY YARD (Allegheny Industrial Track)	YARD	MBS

P&B MAIN TRACK (E) (CONTINUED)				
21.6	BLS	ALLEGHENY	9150 (158)	MBS
23.3	BLS	PARSONS	MBS
24.1	SHAWNEE (Shawnee Team Track)	1300 (22)	MBS
24.5	BLS	BRIER (Brier Knob Spur)	1540 (25)	MBS
24.8	BRIER KNOB	MBS
25.4	ROCKINGHAM	MBS
26.4	BLS	SUMMIT	2470 (42)	MBS
27.7	BLS	HUSKIN (Huskin Spur)	928 (11)	MBS
29.5	BABCOCK JCT (Babcock Spur)	MBS
30.0	BLS	LAUREL	3480 (60)	MBS
31.0	SPRUCE RUN JUNCTION (Spruce Run Secondary)	MBS
31.2	BLS	OLD TOWN	MBS
31.4	OLD TOWN JUNCTION (Vonny Branch)	MBS
31.6	SHADE CREEK (Shade Creek Spur)	400 (3)	MBS
32.0	BLS	SHADE	MBS
32.6	JUNIATA (Begin/End Block)	MBS
32.7	JUNIATA YARD	YARD	YD
34.6	B&O JOINT YARD	YARD	YD

P&B MAIN TRACK (E) (CONTINUED)				
34.7	END P&B RR (BEGIN B&O RR)
34.7 MILES GRAFTON YARD TO END OF B&O INTERCHANGE				

Yard Limits between: MP 0.0 and Grafton; Juniata and MP 34.7

SPRUCE RUN SECONDARY (S)				
MP	BLOCK LIMIT	STATION	SIDING CAPY	RULES
31.0 0.0	SPRUCE RUN JUNCTION (P&B Main Line)	MBS
0.1	OTJ (Begin/End Block)	MBS
2.0	BLS	HUNTERS RIDGE (Hunters Ridge Mine)	600 (11)	MBS
3.3	BLS	SPRUCE RUN	1200 (20)	MBS
5.8	MILL CREEK (Begin/End Block & Mill Creek Industrial Track)	MBS
6.5	MILL CREEK TIPPLE	YARD	YD
7.2	END OF TRACK
		7.2 MILES SPRUCE RUN JUNCTION TO END OF TRACK		

VONNY BRANCH (S)				
MP	BLOCK LIMIT	STATION	SIDING CAPY	RULES
31.4 0.0	OLD TOWN JUNCTION (P&B Main Line)	MBS
0.3	OLD TOWN (Old Town Spur)	460 (8)	YD
0.8	UNIVERSAL	900 (3-3)	YD
0.9	PENS	720 (8)	YD
1.2	TRUCK CENTER	3250 (28)	YD
2.7	HORNERS	700 (4)	YD
2.8	VONNY		YD
2.9	VONNY JCT (Eureka Spur)	300 (3)	YD
3.1	AGWAY	630 (6)	YD
3.2	GLOSSERS	275 (3)	YD
3.9	IRON CITY	425 (4)	YD
4.1	END OF TRACK
		4.1 MILES OLD TOWN JUNCTION TO END OF TRACK		

Yard Limits between: MP 0.0 to End Of Track

Eureka Spur is out of service between MP 0.3 and End of Track

PLEASANTVILLE SECONDARY (N)				
MP	BLOCK LIMIT	STATION	SIDING CAPY	RULES
10.9 0.0	PLEASANTVILLE JUNCTION (P&B Main Line)	WYE	97
0.4	BUCK RUN (Begin/End Block)	MBS
1.1	MOSS CREEK JUNCTION	MBS
1.4	BLS	MAXFIELD	MBS
3.3	BLS	PV	6200 (107)	MBS
3.4	PLEASANTVILLE	MBS
4.3	COAL CREEK JUNCTION (Coal Creek Branch)	MBS
4.4	STONE (Begin/End Block)	MBS
5.6	KEYSTONE POWER	YD
6.5	END OF LOOP TRACK
		6.5 MILES PLEASANTVILLE JUNCTION TO MP 6.5		

Yard Limits between: MP 0.0 and 0.4 on both legs of wye tracks
MP 4.4 and 6.5 including Keystone Power loop track

COAL CREEK BRANCH (W)				
MP	BLOCK LIMIT	STATION	SIDING CAPY	RULES
4.3 0.0	COAL CREEK JUNCTION (Pleasantville Secondary)	MBS
0.1	TIMBER (Begin/End Block)	MBS
1.4	BETH (Begin/End Block & Bethlehem Industrial Track)	MBS
2.2	MINE 78	YARD	YD
2.8	END OF TRACK
		2.8 MILES COAL CREEK JUNCTION TO END OF TRACK		

BABCOCK SPUR (N)				
MP	BLOCK LIMIT	STATION	SIDING CAPY	RULES
29.5 0.0	BABCOCK JCT (P&B Main Line)	MBS
0.8	BABCOCK MINE	YARD	YD
1.3	END OF TRACK
		1.3 MILES BABCOCK JCT TO END OF TRACK		

Yard Limits between: MP 0.0 to End Of Track

OLD TOWN SPUR (S)				
MP	BLOCK LIMIT	STATION	SIDING CAPY	RULES
0.3 0.0	OLD TOWN (Vonny Branch)	YD
0.3	BELMONT	260 (2)	YD
0.4	THOMPSON	400 (6)	YD
0.8	STANDARD	1950 (33)	YD
1.2	END OF TRACK
		1.2 MILES OLDTOWN TO END OF TRACK		

Yard Limits between: MP 0.0 and 1.2

PAINT CREEK BRANCH (S)				
MP	BLOCK LIMIT	STATION	SIDING CAPY	RULES
9.6 0.0	PAINT CREEK JCT (P&B Main Line)	MBS
0.1	PAINT (Begin/End Block)	MBS
0.7	CUB RUN	MBS
1.1	ASHTOLA (Begin/End Block & Curry Mill Industrial Track)	MBS
1.4	CURRY MILL	YARD	YD
1.9	MILL SIDING	2100 (35)	YD
2.5	END OF TRACK
		2.5 MILES PAINT CREEK JCT TO END OF TRACK		

Yard Limits between: MP 1.1 and 2.5

MOSS CREEK BRANCH (E)				
MP	BLOCK LIMIT	STATION	SIDING CAPY	RULES
1.1 0.0	MOSS CREEK JCT (Pleasantville Sec.)	MBS
0.6	WOODLAND #2	YD
2.0	MOSS CREEK	1700 (25)	YD
2.6	END OF TRACK
		2.6 MILES MOSS CREEK JCT TO END OF TRACK		

Yard Limits between: MP 0.0 and 2.6

LOCATION OF PUBLIC AND PRIVATE TRACKS AND CAPACITIES NOT SHOWN ON TIMETABLE

NAME	MILEPOST	CAR CAPY	OPEN END
Grafton Industrial Track			
Ag Co-ops, Inc	0.4	31	E
Grafton Imports, Inc	0.5	3	E
Grafton Dockside	0.9	27	Both
Highland Industrial Track			
TOFC Yard	5.3	35	E
Sweets Candy Co.	5.3	4	E
Swift Foods, Inc.	5.5	16Sc, 17Rf	W
Texaco Oil Co.	5.8	15	W
Reitz Salvage, Inc.	5.9	9	W
Shawnee Team Track			
Team Track	24.4	3	E
Spruce Run Secondary			
PBS Coals, Inc.	6.5	50	B
Coal Creek Branch			
Mine 78	2.2	60	B
Babcock Spur			
Babcock Mines, Inc.	0.8	26	N
Old Town Spur			
Standard Oil, Inc.	0.8	14	S
Pleasantville Secondary			
Keystone Power Co.	5.6	100	Loop
Paint Creek Branch			
Babcock Lumber Co. Curry Mill	1.4	20 Wchip & logs, 10 Box	B
Huntingdon Paper Spur			
	14.5	20 Wchip, 10 Box	W
Moss Creek Branch			
Moss Creek Lumber	2.0	25	B

PENNSYLVANIA & BERWIND RR EMPLOYEE TIMETABLE

SPECIAL INSTRUCTIONS

104.1 – HAND OPERATED SWITCHES

Switch located at	Connecting	with	Normal is for movement to
Buck Run	Pleasantville Sec	Wye Tracks	East Leg Wye
Coal Creek Jct	Coal Creek Branch	Pleasantville Sec	Pleasantville Sec
Old Town Siding	Old Town Spur	Old Town Siding	as last used

106.1 STANDARD CLEARANCE

Employees are prohibited from riding the side of equipment account of non-standard clearances at the following locations:

Ag Co-ops, Inc	–	Grafton Industrial Track
Texaco Oil Co	–	Highland Industrial Track
Eminwes Furniture Co	--	Shade Creek Spur

111.1 SIDINGS -- SPEED

All sidings 20 MPH

Except:

Old Town	10 MPH
Spruce Run	10 MPH
Mill Siding	15 MPH
Moss Creek	10 MPH

113.1 INDUSTRIAL TRACKS -- SPEED

All industrial tracks 20 MPH

Except:

Millcreek Industrial Track ...	10 MPH
Curry Mill Industrial Track ..	15 MPH

124. MAXIMIM AUTHORIZED SPEED – ALL TRACKS

MAIN LINE

<u>Between</u>	<u>Maximum MPH</u>
Grafton Yard – MP 34.7	50
Except:	
Grafton – MP 3.6	30
MP 3.6 – MP 5.2	45
MP 6.3 – MP 7.3	35
Except: Curve at MP 6.4	25
MP 7.3 – MP 8.0	40
MP 8.0 – MP 10.1	30
Except: Curve at MP 8.4	25
MP 10.1 – MP 14.1	40
Except: Curve at MP 12.8	30
MP 14.1 –MP 14.7	35
MP 16.2 – MP 17.6	35
MP 19.5 – MP 21.1	40
Parsons – MP 24.1	30
MP 24.1 – MP 24.6	40
MP 24.6 – MP 29.8	35
Except: Curve at MP 25.5	
Curve MP 26.5 to MP 26.7	
Curves MP 27.8 to MP 28.1	25
MP 29.8 – MP 31.4	40
MP 31.4 – Juniata	35

SPRUCE RUN SECONDARY

<u>Between</u>	<u>Maximum MPH</u>
MP 0.0 -- Millcreek	25
Except:	
Southward Trains MP 4.4 to MP 1.0	20
Curve at MP 2.1	10
Curve at MP 3.0	10

PLEASANTVILLE SECONDARY

<u>Between</u>	<u>Maximum MPH</u>
Buck Run – Stone	40
Except:	
MP 0.4 – MP 2.8	20
MP 4.0 – Stone	30
Stone – MP 5.3	30 (Yard Rules)
MP 5.3 – MP 6.5	15
Other: Keystone Power unloading pit	6

COAL CREEK BRANCH

<u>Between</u>	<u>Maximum MPH</u>
Coal Creek Junction – Beth	20
Except:	
Eastward trains MP 1.4 to MP 0.8	10
Eastward trains MP 0.8 to Timber	15
Curve at MP 0.5	10
Curve at MP 1.2	15

VONNY BRANCH

<u>Between</u>	<u>Maximum MPH</u>
MP 0.0 – MP 2.5	20
Except:	
Vonny Tunnel	10
MP 2.5 -- Iron City	10
Iron City – End of Track	5

BABCOCK SPUR

<u>Between</u>	<u>Maximum MPH</u>
MP 0.0 – End of Track	20
Except:	
Curve at MP 0.5	10

PAINT CREEK BRANCH

<u>Between</u>	<u>Maximum MPH</u>
MP 0.0 – End of Track	15

MOSS CREEK BRANCH

<u>Between</u>	<u>Maximum MPH</u>
MP 0.0 – End of Track	10

OLD TOWN SPUR

<u>Between</u>	<u>Maximum MPH</u>
MP 0.0 – End of Track	15
Except:	
Northward trains MP 0.8 to MP 0.5	10
<u>ALL OTHER SPURS</u>	10

OTHER SPEED RESTRICTIONS:

West leg of wye at Grafton	5
Run-around track at Iron City	5

EQUIPMENT RESTRICTIONS – ENGINES -- CARS

Engines with six axles are prohibited as follows:

- Vonny Branch - south of MP 1.3
- Moss Creek Branch
- Old Town Spur

Cars are restricted account length as indicated at the following locations:

- Old Town Spur – 75 feet or longer

Loaded coal trains are restricted to a maximum authorized speed of 40 MPH. Empty trains do NOT have this restriction.

MISCELLANEOUS OPERATING INSTRUCTIONS:

All terminal yards:

All trains approaching to enter yard limits at Grafton, Allegheny, and Juniata must contact the yardmaster regarding movement instructions and authority.

All switches, except as otherwise noted, may be left as last used.

Trains and Engines are governed by Rule 80 and 93. Trains must not exceed 20 MPH within terminal yard limits. Light engines must not exceed 30MPH within yard limits.

Juniata yard:

Trains handling live cattle in stockcars from Pens will place cars on yard track JT6 for servicing.

Livestock trains must not be delayed in terminal for more than 6 hours.

Interchange traffic must contact the B&O yardmaster before entering the Joint Yard.

Grafton Yard:

Switches on the east end of Grafton Yard, after being used, must be restored to position found. The normal position for the Grafton siding switch and the switch at the west end of GT1 is lined for movements to the main yard tracks.

Interchange traffic must contact the N&W yardmaster before entering the Joint Yard.

Allegheny Yard:

Allegheny yard contains two (2) yards with assigned leads. Allegheny West Yard contains tracks AW1 through AW10. Trains will use Allegheny West Yard Lead to build trains and Allegheny Siding for headroom, if needed. Allegheny East Yard contains tracks AE1 through AE10 and will use the Back Lead to build trains and Allegheny East Yard Lead for headroom, if needed. All trains with eastbound consists will use the Allegheny West Yard. All westbound consists will use Allegheny East Yard.

Allegheny Siding:

Allegheny Siding is **not** located in Yard Limits of Allegheny Yard and is governed by MBS rules. Trains entering Allegheny Siding from the yard must obtain permission from the Dispatcher.

A sign displaying 'SL' is located near each end of Allegheny Siding that indicates the siding limit behind which standing trains must remain while stopped to prevent fouling the Allegheny yard switching leads.

Old Town:

Grade crossings in Old Town on the Old Town Spur and Vonny Branch must not be blocked for longer than 10 minutes. Crossing must be opened if 10 minutes is exceeded.

Pleasantville Junction:

Eastward and Westward trains may use the wye at Pleasantville Junction for switching Grundys Spur or other needed movements. Obtain permission of the dispatcher to prevent conflicting movements with trains on the Pleasantville Secondary.

Keystone Power:

Unless otherwise provided, trains other than Keystone Power unit coal trains will not move over the unloading pit on the loop track of the Keystone Power Plant.

Track between MP 4.4 and 6.5 is governed by Rule 93, not exceeding 30 MPH. Do not exceed 6 MPH while moving over and unloading on the unloading pit.

During the time that unit coal trains are unloading at the Keystone Power Plant, a crewmember must be in position at all times to observe the unloading pit. If the coal exceeds the top of the top of the rail or the car fails to unload properly due to slow coal unloading, the train must immediately be stopped until the level of coal runs down.

Coal Creek Branch:

Trains descending grade between MP 1.4 and Coal Creek Junction must operate with a minimum of 24 axles of operative dynamic brakes. Trailing tonnage is limited to 5200 tons.

Pleasantville:

Standing trains on Pleasantville Siding must not excessively block crossings. Trains waiting at Pleasantville to be met or passed by another train must pull clear or stop clear of these crossings whenever practical. If the train is to remain at this location over 15 minutes, these crossings must be opened to allow traffic to pass.

Babcock Spur:

Switches will be left lined and locked for straightaway movements on this spur.

Vonny Branch:

All reverse movements on and going from Old Town Siding to all industries must have an employee riding the rear car. The employee must ensure that the crossing is clear from vehicular traffic at Universal Sugar before movement is made into the plant.

Movements are governed by Rule 93 and are under the supervision of the Dispatcher. Trains returning from Vonny must contact Dispatcher before entering Vonny Tunnel to determine the location of any conflicting movements by other trains in the yard limits.

Eureka Spur is out of service between MP 0.3 and end of track. Trains or engines are prohibited beyond MP 0.3.

Paint Creek Branch:

Trains descending grade between MP 1.2 and Paint Creek Junction must operate with a minimum of 18 axles of operative dynamic brakes when trailing tonnage exceeds 1000 trailing tons. Trailing tonnage is limited to 2500 tons. Locomotive independent brakes must be used when completing stops while descending grade between MP 1.2 and Paint Creek Junction.

Moss Creek Branch:

Trains descending grade between MP 2.0 and Moss Creek Junction must operate with a minimum of 16 axles of operative dynamic brakes when trailing tonnage exceeds 800 tons. Trailing tonnage is limited to 2300 tons.

Industrial spur at Woodland #2 (MP 0.6) is out of service to all trains and track cars.

STATIONS, INDUSTRIES, & COMMODITIES

Station	Location	Industry Agent	I / O	Cargo	Origination-Destination Station / Industry Agent / Train Symbol - Route Code
Agway	Vonny Branch	Agway, Inc.	I	Wheat	Grafton/Ag-Co-ops,Inc./20,17,14
Allegheny	Allegheny Industrial	Allegheny Steel, Inc	I	Coal	Mine 78
			O	Steel	Grafton / Grafton Imports, Inc / 6,3,14
Babcock Mine	Babcock Spur	Babcock Mines, Inc.	O	Coal	Grafton/ Grafton Dockside / 20,(17 or 10,2),14
Belmont	Old Town Spur	Belmont Lumber Co.	I	Lumber	Curry Mill / Babcock Lumber /
Brier	Brier Knob Spur	Purina Chow, Inc.	I	Grain	Grafton / Ag Co-ops, Inc. / 14,10,6
Curry Mill	Paint Creek Branch	Babcock Lumber Co.	O	Lumber	Belmont/Belmont Lumber Co.
			O	Woodchips	Union / Union Paper Co
			I	Logs	Grafton / Arrow Lumber Co
Vonny Jct	Vonny Branch	Eureka Store/ Berwind, Inc.	I	Goods	Grafton / Grafton Imports, Inc./ 14,12,20
Glossers	Vonny Branch	Glosser Brothers Co.	I	Goods	Grafton / Grafton Imports, Inc./ 14,12,20
Grafton	Grafton Industrial Track	Grafton Dockside, Inc.	I	Coal	Hunters Ridge / HR Mine / 20,17,14 Mine #78 / Bethlehem Steel / 11,8,14 Babcock Mine / 20,(17 or 10,2),14
			I	Steel	Allegheny/Allegheny Steel, Inc/6,3,1,14
		Grafton Imports, Inc.	O	Goods	Shade / Eminwes Furniture Co./ 14,12, 20
			O	Grain	Brier / Purina Chow, Inc./ 14,10,6
			O	Logs	Curry Mill / Babcock Lumber Co
Highland	Highland Industrial Track	Reitz Salvage, Inc.	I	Scrap Metal	Horners/ Horners, Inc./16,12,20
		Swift Foods, Inc.	I	Cattle	Pens / Team Track / 26,22,16,12
			O	Meat	Shawnee / Team Track / 16,10,6,3
		Sweets Candy Co.	I	Sugar	Universal / Universal Sugar / 26,17,16,12
		Texaco Oil Co.	I	Oil	Standard / Standard Oil, Inc./ 26,21,16,12
		TOFC Yard	I	TOFC	Truck Center / Trans / 26,19,15
Horners	Vonny Branch	Horners, Inc.	O	Scrap Metal	Highland/Reitz Salvage/20,17,16,12
Hunters Ridge	Spruce Run Secondary	HR Mine Berwind Coal Co	O	Coal	Thompson / Thompson Coal Sales/ 20,26 Grafton / Grafton Dockside, Inc./ 20,(17 or 10,2),14
Huntingdon	Main Track	Huntingdon Paper Co.	O	Paper	Universal Sugar / Shawnee Team Track
			I	Woodchips	Curry Mill / Babcock Lumber Co
Millcreek	Spruce Run Secondary	PBS Coals, Inc.	O	Coal	Stone / Keystone Power Co. / 7,25,5 OR 7,24,23
Mine 78	Coal Creek Branch	Bethlehem Steel, Inc.	O	Coal	Grafton / Grafton Dockside, Inc. / 11,8,14
Moss Creek	Moss Creek Branch	Moss Creek Lumber Co.	O	Logs	Curry Mill / Babcock Lumber Co. / 14
Pens	Vonny Branch	Team Track	O	Cattle	Highland / Swift Foods, Inc. / 26,22,16,12
Grundys	Main Track	Grundys Cement Co.	I	Gravel	Huskin / Huskin Gravel / (18,3,12) OR 17,12
Shade	Main Track	Eminwes Furniture Co.	I	Furniture	Grafton / Grafton Imports, Inc./ 14,12,20
Shawnee	Main Track	Team Track	O	Paper	Universal / Universal Sugar / 6,3,26,10
			O	Lumber	Belmont / Belmont Lumber / 6,3,26,10
			I	Meat	Highland / Swift Foods, Inc. / 16,10,6,3
Standard	Old Town Spur	Standard Oil, Inc.	O	Oil	Highland / Texaco Oil Co./ 26,21,16,12
Stone	Pleasantville Secondary	Keystone Power Co.	I	Coal	Millcreek / PBS Coals, Inc. / 7,25,5 OR 7,24,23
Thompson	Old Town Spur	Thompson Coal Sales	I	Coal	Hunters Ridge / Berwind Coal Co. / 20,26
Truck Center	Vonny Branch	Trans Industries	O	TOFC	Highland / TOFC Yard / 26,19,15
Universal	Vonny Branch	Universal Sugar	I	Paper	Shawnee / Team Track / 6,3,26,10
			O	Sugar	Highland / Sweets Candy Co. / 26,17,16,12

PENNSYLVANIA & BERWIND RR
TRAIN SYMBOLS, DESTINATIONS, & SERVICE AREAS

Route Code	Symbol	Origin Station	Destination Station	Type	Comments
1	ALCCC	Allegheny Yard	Mine 78	Coal	Empties to Mine
2	ALGRC	Allegheny Yard	Grafton Yard	Coal	Export to Docks
3	ALGRF	Allegheny Yard	Grafton Yard	Forwarder	Yard Transfer
4	ALJUF	Allegheny Yard	Juniata Yard	Forwarder	Yard Transfer
5	ALKYC	Allegheny Yard	Stone	Coal	Loads to Keystone Power Co.
6	ALLO	Allegheny Yard	Allegheny Yard	Local	Local
7	ALMCC	Allegheny Yard	Millcreek	Coal	Empties to Mine
8	CCGRC	Mine 78	Grafton Yard	Coal	Loads to Docks
9	CCALC	Mine 78	Allegheny Yard	Coal	Loads to Yard
10	GRALF	Grafton Yard	Allegheny Yard	Forwarder	Yard Transfer
11	GRCCC	Grafton Yard	Mine 78	Coal	Empties to Mine
12	GRJUF	Grafton Yard	Juniata Yard	Forwarder	Yard Transfer
13	GRKYC	Grafton Yard	Stone	Coal	Loads to Keystone Power Co.
14	GRLO	Grafton Yard	Grafton Yard	Local	Grafton Local
15	HIJUQ	Highland	Juniata Yard	TOFC	Empty TOFC to Yard
16	HILO	Grafton	Highland	Local	Grafton to Highland Local and return
17	JUGRF	Juniata Yard	Grafton Yard	Forwarder	Yard Transfer
18	JUALF	Juniata Yard	Allegheny Yard	Forwarder	Yard Transfer
19	JUHIQ	Juniata Yard	Highland	TOFC	TOFC to TOFC Yard
20	JULO	Juniata Yard	Juniata Yard	Local	Juniata Local
21	JUHIO	Juniata Yard	Highland	Oil	Unit Oil to Texaco
22	JUHIL	Juniata Yard	Highland	Livestock	Unit Livestock to Swift
23	KYALC	Stone	Allegheny Yard	Coal	Empties to Yard
24	MCKYC	Millcreek	Stone	Coal	Loads to Keystone Power Co.
25	MCALC	Millcreek	Allegheny Yard	Coal	Loads to Yard
26	OTLO	Juniata Yard	Old Town	Local	Juniata to Old Town Local and return

GRUNDYS = ALGRF OR JUGRF

HUKSINS = JUALF OR JUGRF

EMINWES, BABCOCK, HUNTERS RIDGE, VONNY = JULO

ENINWES, VONNY BRANCH, OLDTOWN SPUR = OTLO

PENNSYLVANIA & BERWIND RR SYSTEM TRACK CHART

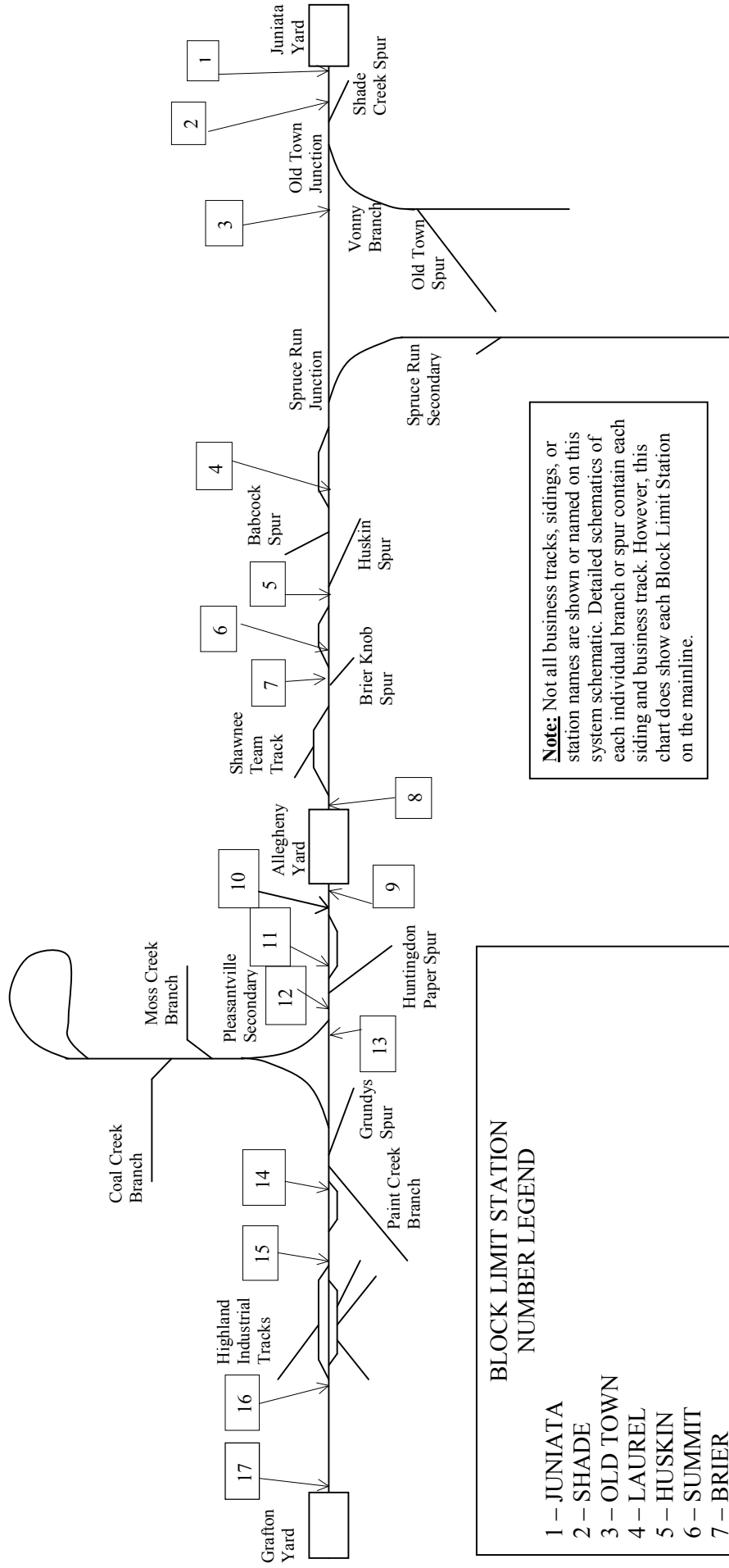

Note: Not all business tracks, sidings, or station names are shown or named on this system schematic. Detailed schematics of each individual branch or spur contain each siding and business track. However, this chart does show each Block Limit Station on the mainline.

BLOCK LIMIT STATION NUMBER LEGEND	
1	- JUNIATA
2	- SHADE
3	- OLD TOWN
4	- LAUREL
5	- HUSKIN
6	- SUMMIT
7	- BRIER
8	- PARSONS
9	- ALLEGHENY
10	- MAPLETON
11	- EVERETT
12	- MT UNION
13	-- GRUNDYS
14	- TROUT
15	- HIGHLAND
16	- CUMBERLAND
17	-- GRAFTON

PENNSYLVANIA & BERWIND RR TRACK CHART

JUNIATA YARD

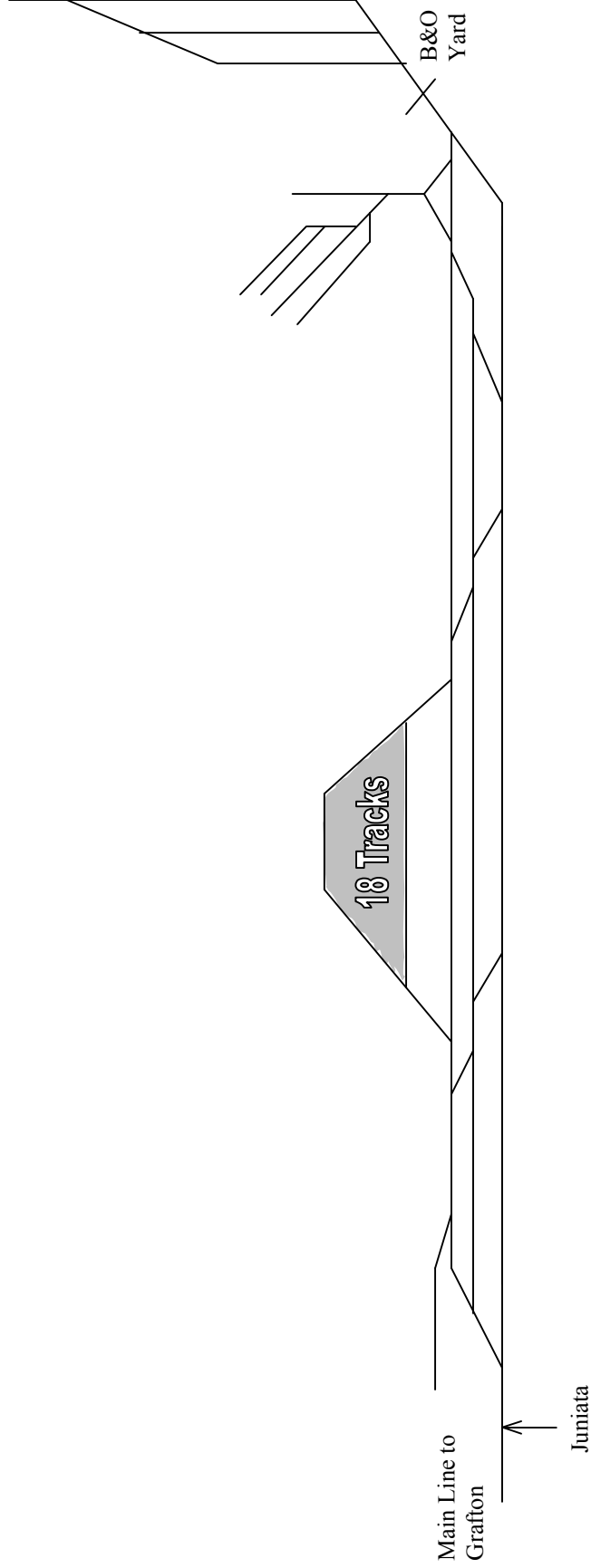

Note: Stations that are designated as Block Limit Stations or Begin/End Block Limits appear with an arrow marking the location of the block limit.

PENNSYLVANIA & BERWIND RR TRACK CHART

VONNY BRANCH

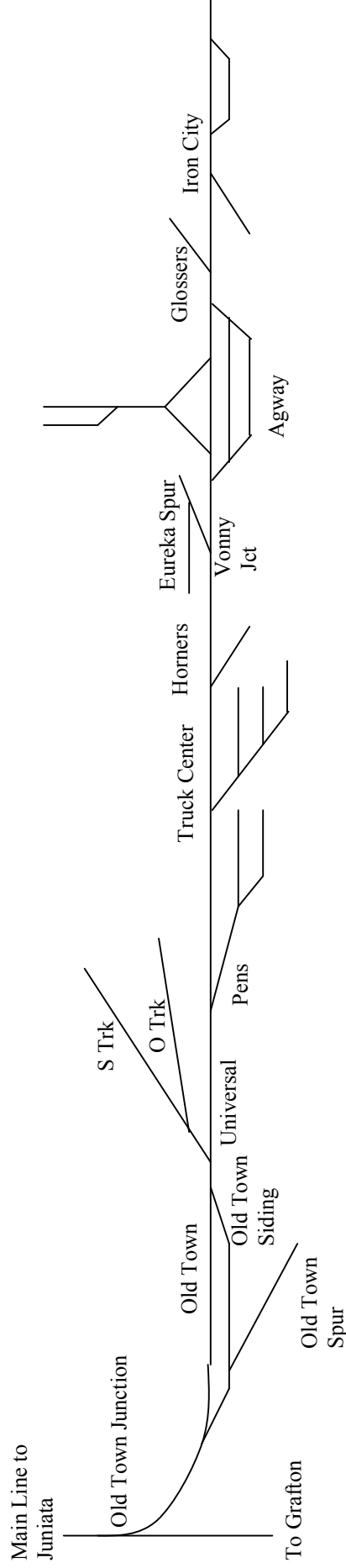

Note: Stations that are designated as Block Limit Stations or Begin/End Block Limits appear with an arrow marking the location of the block limit.

PENNSYLVANIA & BERWIND RR TRACK CHART

OLD TOWN SPUR

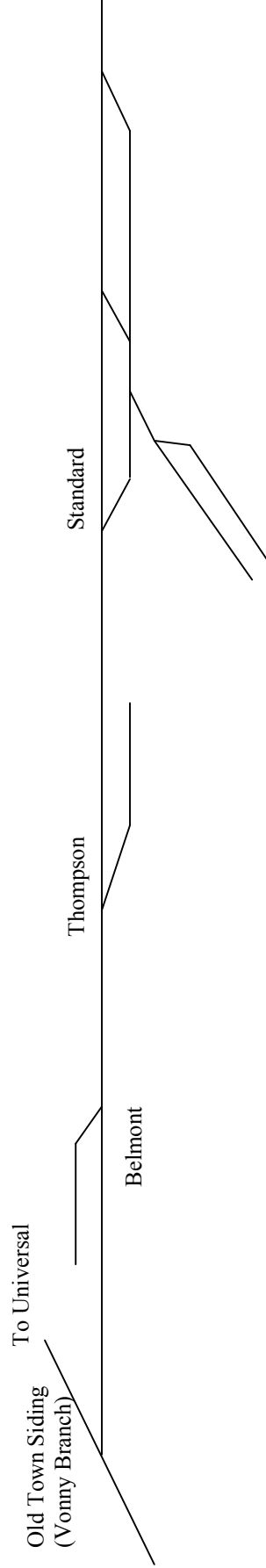
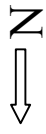

Note: Stations that are designated as Block Limit Stations or Begin/End Block Limits appear with an arrow marking the location of the block limit.

PENNSYLVANIA & BERWIND RR TRACK CHART

SPRUCE RUN SECONDARY

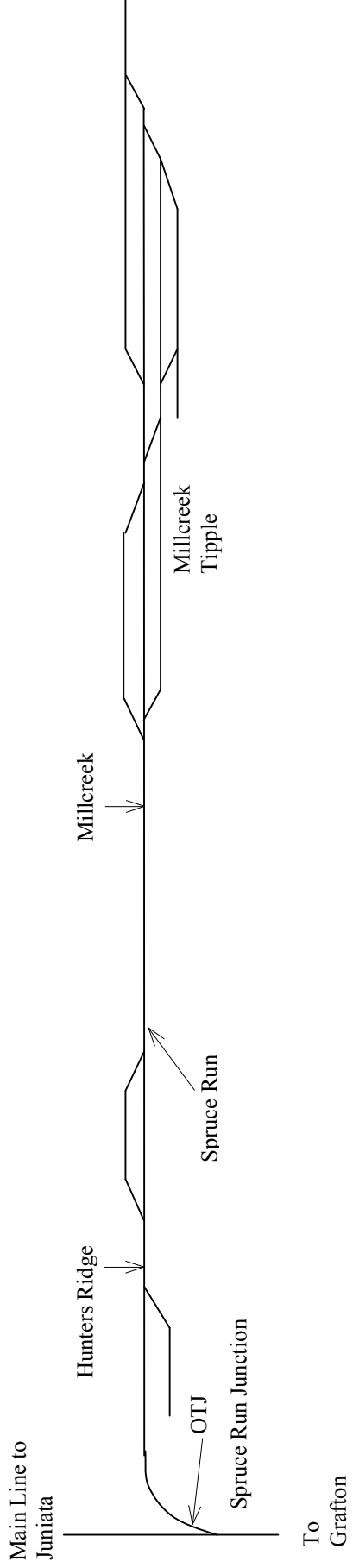

Note: Stations that are designated as Block Limit Stations or Begin/End Block Limits appear with an arrow marking the location of the block limit.

PENNSYLVANIA & BERWIND RR TRACK CHART

BABCOCK SPUR



To Grafton

Babcock

Main Line
to Juniata

Babcock
Mine



Note: Stations that are designated as Block Limit Stations or Begin/End Block Limits appear with an arrow marking the location of the block limit.

PENNSYLVANIA & BERWIND RR TRACK CHART

ALLEGHENY YARD

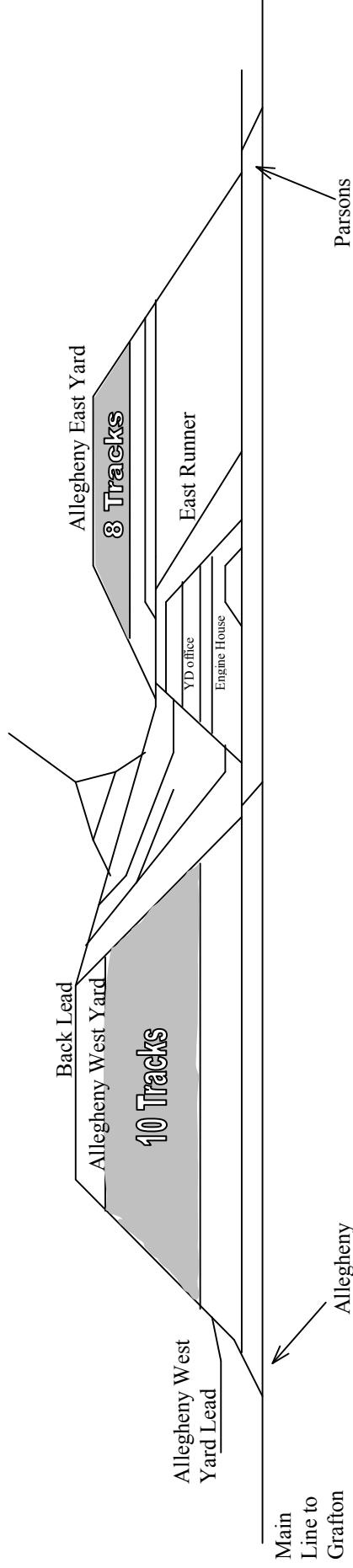

Note: Stations that are designated as Block Limit Stations or Begin/End Block Limits appear with an arrow marking the location of the block limit.

PENNSYLVANIA & BERWIND RR TRACK CHART

ALLEGHENY INDUSTRIAL TRACK

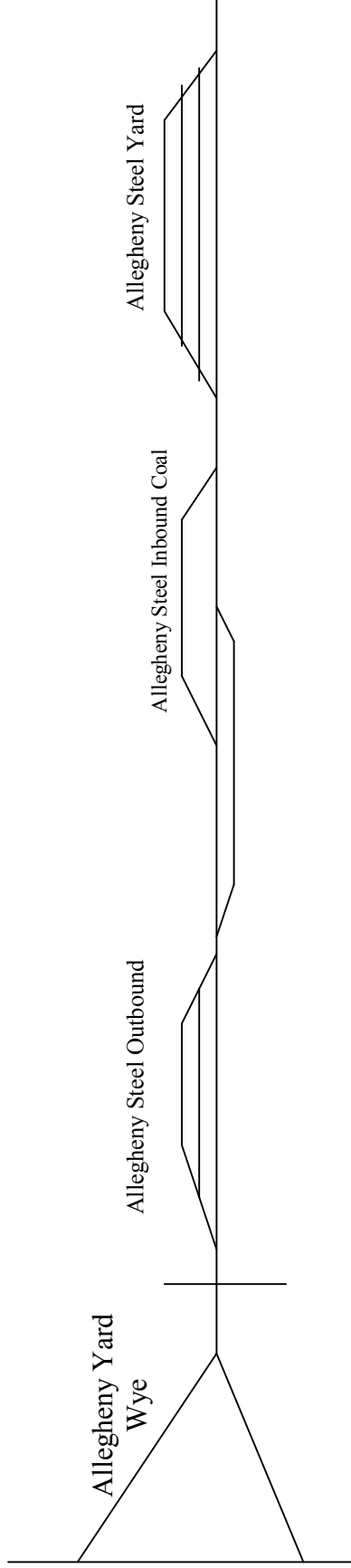

Note: Stations that are designated as Block Limit Stations or Begin/End Block Limits appear with an arrow marking the location of the block limit.

PENNSYLVANIA & BERWIND RR TRACK CHART

PLEASANTVILLE SECONDARY

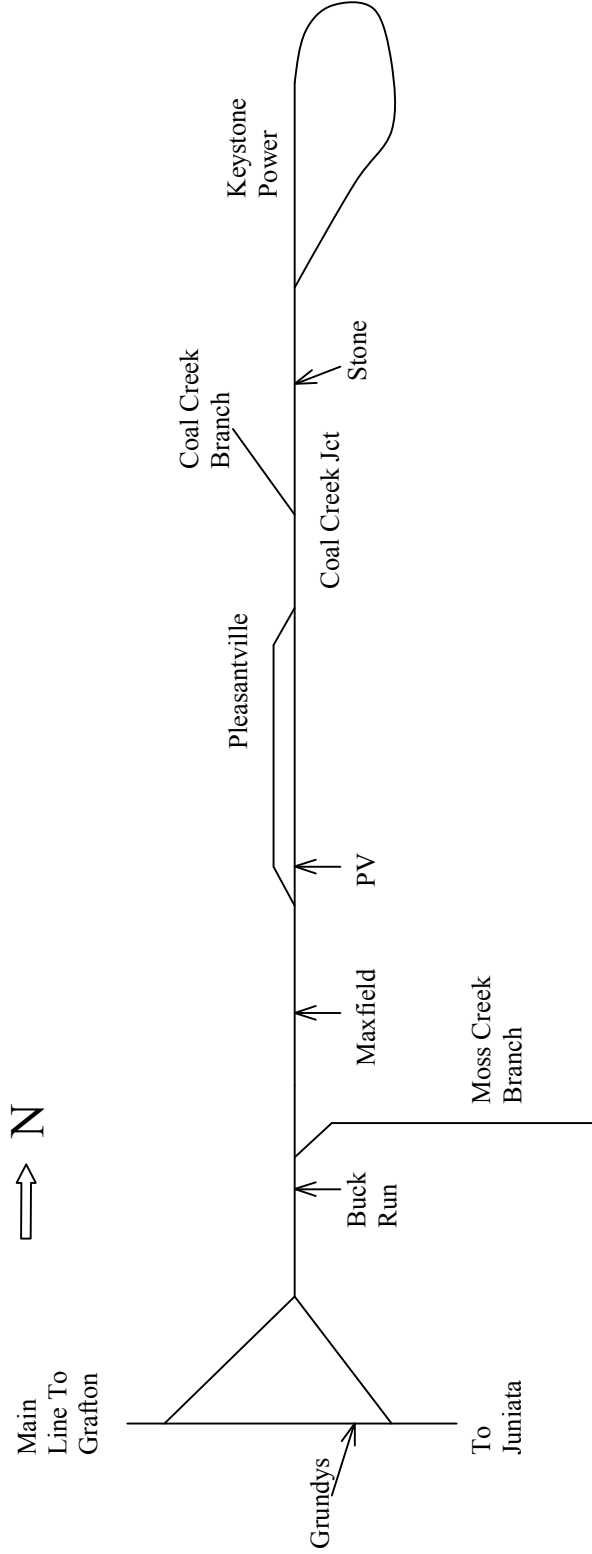

Note: Stations that are designated as Block Limit Stations or Begin/End Block Limits appear with an arrow marking the location of the block limit.

PENNSYLVANIA & BERWIND RR TRACK CHART

COAL CREEK BRANCH

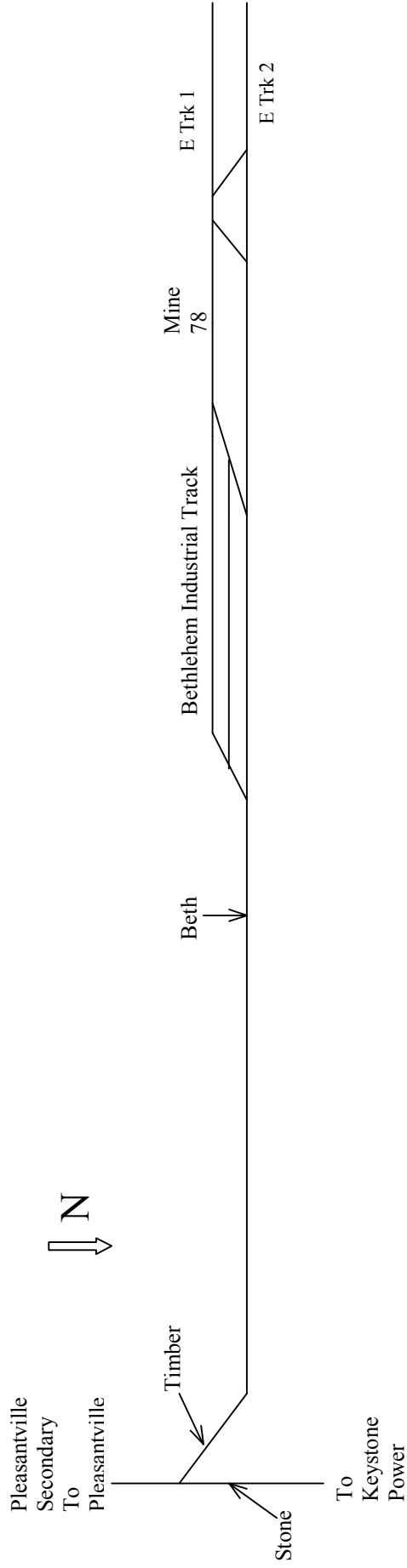

Note: Stations that are designated as Block Limit Stations or Begin/End Block Limits appear with an arrow marking the location of the block limit.

PENNSYLVANIA & BERWIND RR TRACK CHART

MOSS CREEK BRANCH

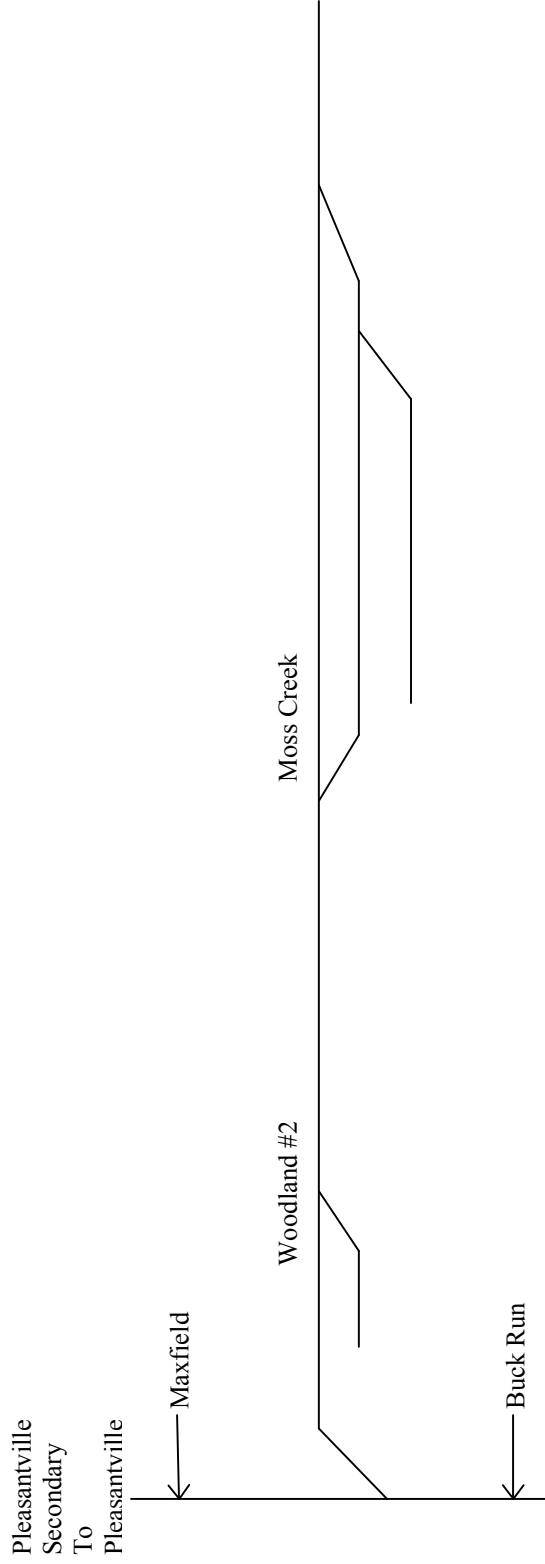

Note: Stations that are designated as Block Limit Stations or Begin/End Block Limits appear with an arrow marking the location of the block limit.

PENNSYLVANIA & BERWIND RR TRACK CHART

PAINT CREEK BRANCH

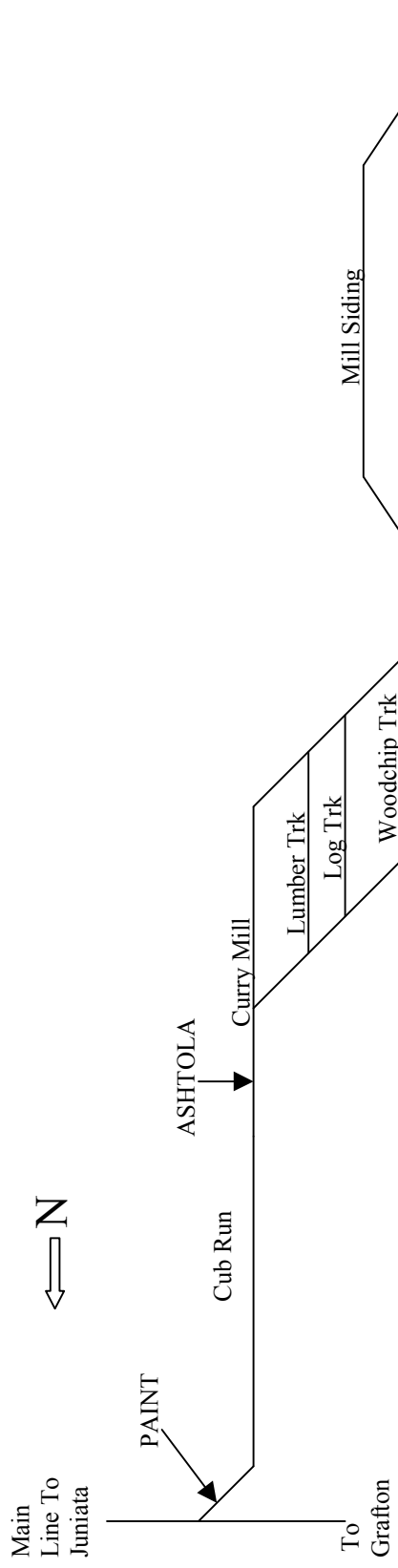

Note: Stations that are designated as Block Limit Stations or Begin/End Block Limits appear with an arrow marking the location of the block limit.

PENNSYLVANIA & BERWIND RR TRACK CHART

HIGHLAND INDUSTRIAL TRACK

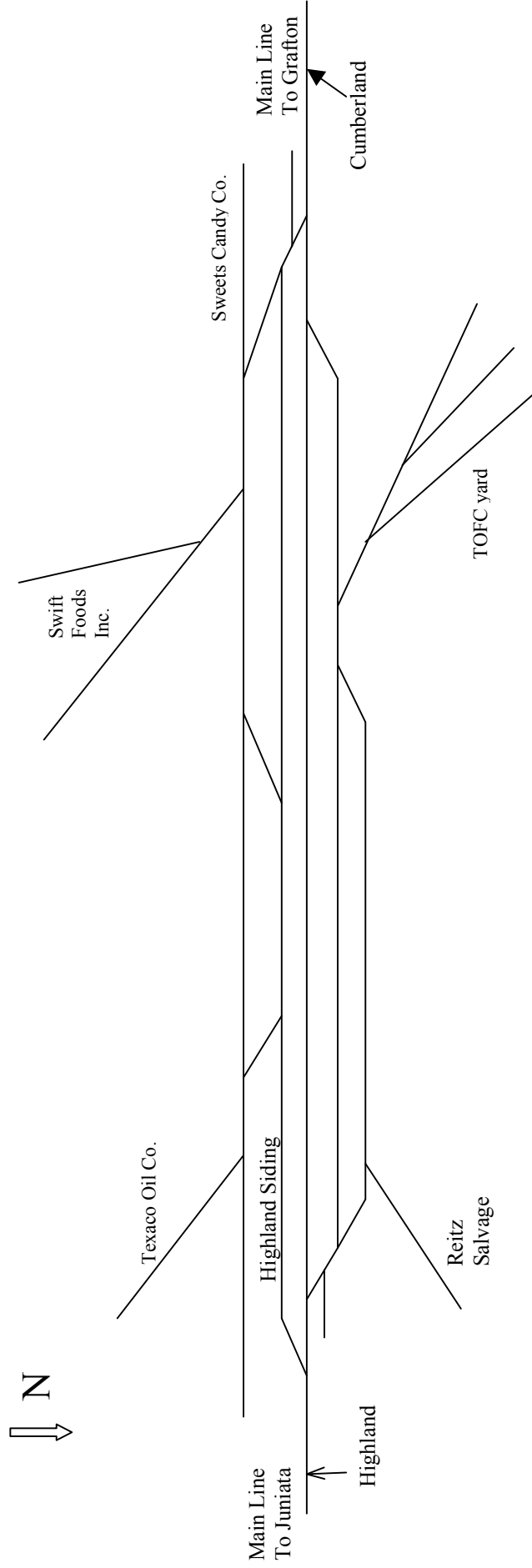

Note: Stations that are designated as Block Limit Stations or Begin/End Block Limits appear with an arrow marking the location of the block limit.

PENNSYLVANIA & BERWIND RR TRACK CHART

GRAFTON YARD

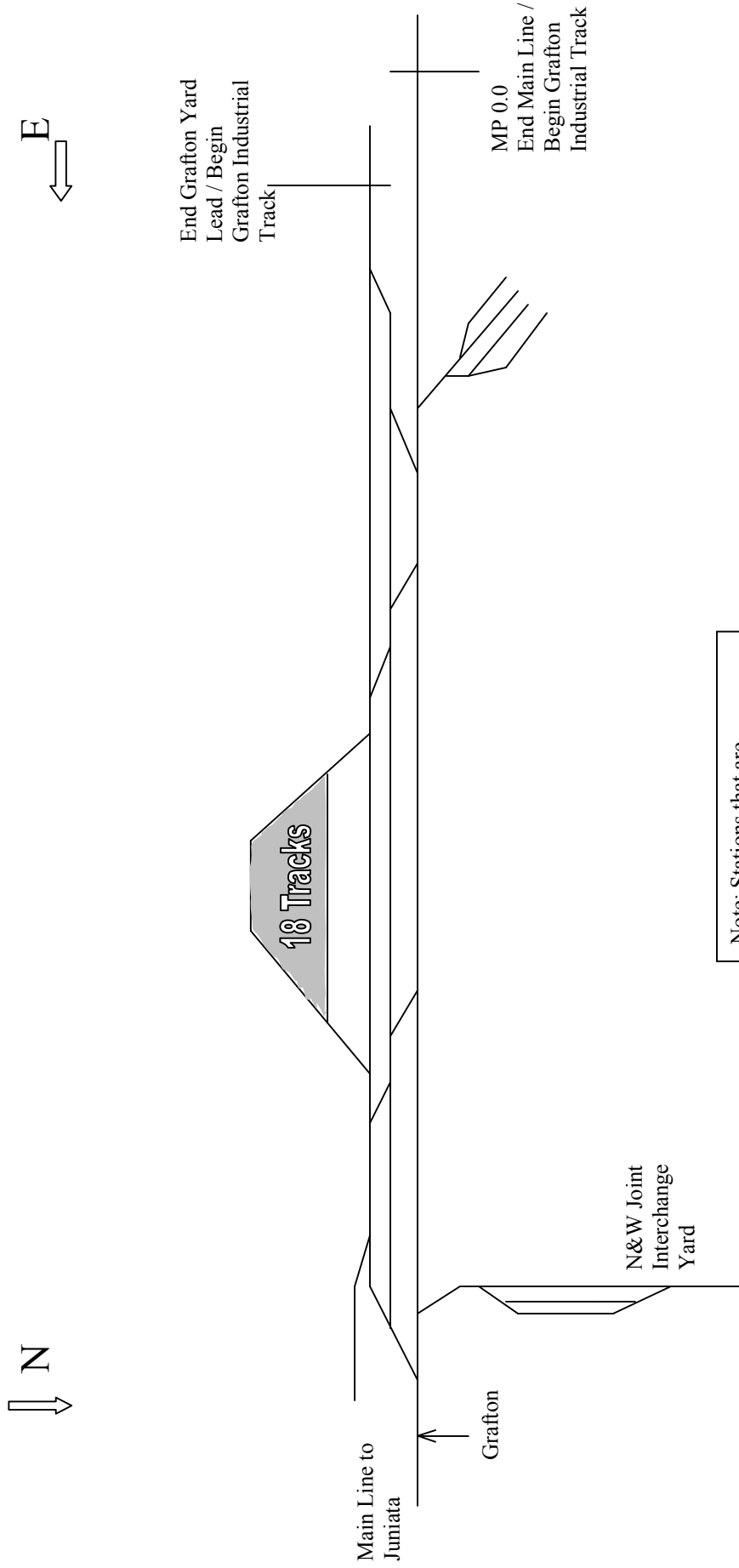

Note: Stations that are designated as Block Limit Stations or Begin/End Block Limits appear with an arrow marking the location of the block limit.

PENNSYLVANIA & BERWIND RR TRACK CHART

GRAFTON INDUSTRIAL TRACK

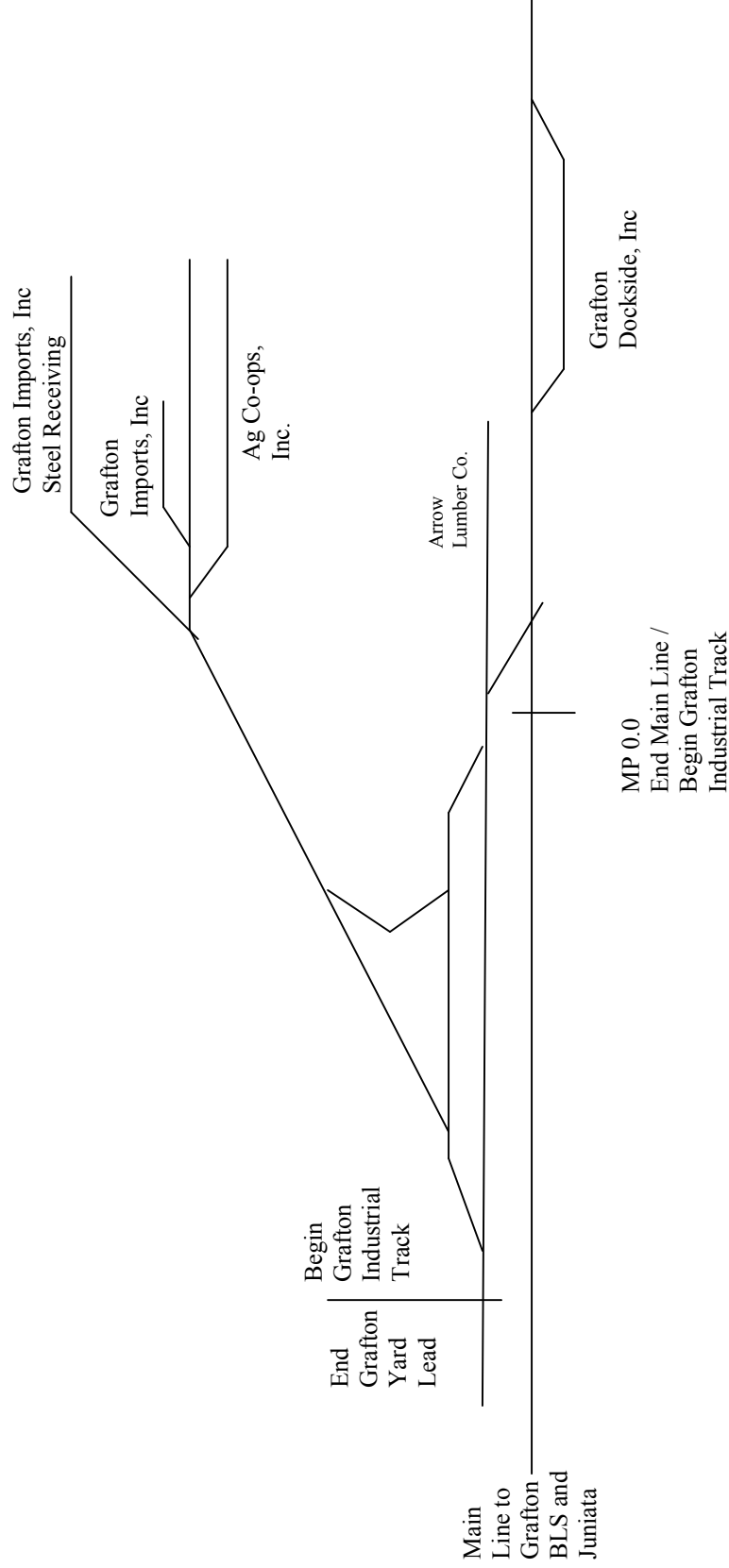

Note: Stations that are designated as Block Limit Stations or Begin/End Block Limits appear with an arrow marking the location of the block limit.